

The BIG SMALL BLOCK

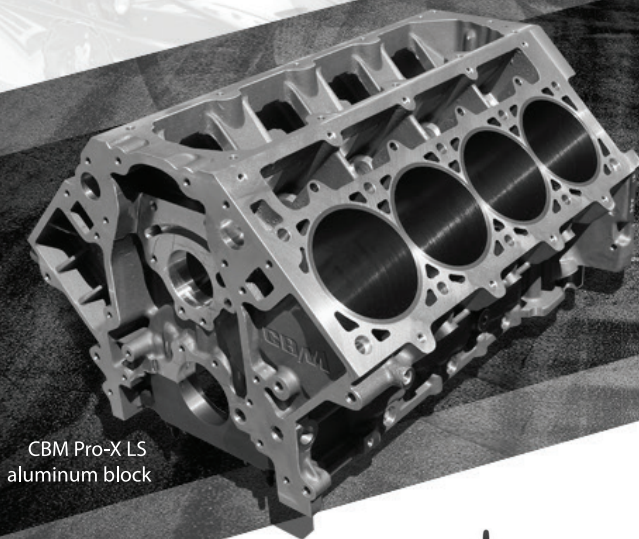

Pro-XTM LS



CBM Pro-X LS
aluminum block

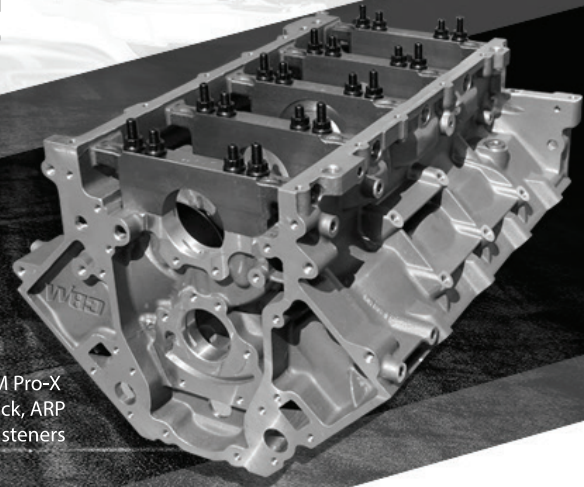

CBM Pro-X
LS block, ARP
fasteners



FEATURES:

- ❖ Weighs 105 lbs.
- ❖ ARP Fastener option.
- ❖ True priority main oiling.
- ❖ Standard 4,400" bore spacing.
- ❖ CNC - machined aluminum block.
- ❖ Extra thick Siamese cylinder bores.

CNC MACHINED CAST ALUMINUM PRO-X LS BLOCK

The CBM Motorsports™ Pro-X aluminum engine block was designed for high performance, durability and as an alternative to the heavy weight of a GM LSX cast iron block. Features include siamese cylinder bores and a semi-finished deck height. The CBM Motorsports™ Pro-X engine block can accept a maximum stroke of 4.250 in., a maximum bore of 4.200 in., and can support displacements of 454 cu. in. or more. Using computer aided engineering and design these CNC machined aluminum blocks can handle all the horsepower and torque needed for racing applications or all out street performance.

Every CBM Motorsports™ Pro-X aluminum engine block must pass extensive quality control from the beginning to the end of the manufacturing process. CBM Pro-X blocks are available with a semi or fully machined finish and accept all Gen III and IV LS-style cylinder heads, crankshafts, camshafts, and other components.

Sign up
for our
Newsletter



CBMmotorsports.com

CBM Motorsports™ 725 S. La Cadena Drive Colton CA 92324 t 909.291.7550 f 909.291.7554

